

E.P.R. S.R.L.

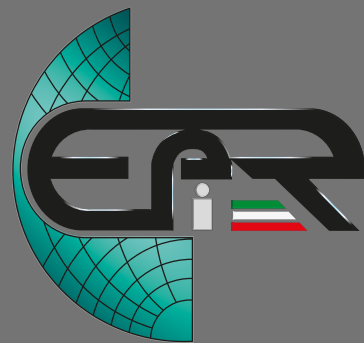

TRASMISSIONI CARDANICHE - GIUNTI A DENTI  
UNIVERSAL DRIVESHAFTS - GEAR COUPLINGS

# Cardan



Soluciones Integrales en Transmisiones Cardan



E0519

# TRASMISSIONI CARDANICHE AD ELEVATE PRESTAZIONI

# HIGH PERFORMANCES UNIVERSAL DRIVESHAFTS



Questo catalogo si riferisce alla attuale produzione di cardani della E.P.R., e fornisce una descrizione delle loro specifiche tecniche per un'opportuna selezione degli stessi. Tuttavia siamo sempre a vostra disposizione per eventuali suggerimenti e chiarimenti per aiutarvi nella scelta. La presente edizione sostituisce tutte le precedenti. LA EPR SI RISERVA DI MODIFICARE OGNI SPECIFICA TECNICA CONTENUTA, SENZA PREAVVISO. Ogni riproduzione, anche parziale, del presente catalogo viola le leggi sul copyright e sarà perseguito a termini di legge. Pubblicato da EPR S.R.L. Stampato in Italia.



*This catalogue relates to EPR's present production of Universal shafts, and provides a description of their technical specification in order for a proper selection to be made. By the way, we are always at your disposition to make suggestions for your choice and provide with you any further information requested. The present edition supersedes all previous editions. EPR RESERVE THE RIGHT TO CHANGE ANY TECHNICAL SPECIFICATION CONTAINED HERE IN, WITHOUT NOTICE. Any reproduction, even partial, of the present catalogue violates the copyright and will therefore be prosecuted. Published by EPR S.R.L.. Printed in Italy.*

WE  
SPIN  
YOUR  
WORLD

# 1. ENGINEERING

# ENGINEERING

Questo particolare giunto deve il nome al suo eclettico inventore (Gerolamo Cardano, 1501 - 1576). Il cardano permette di trasferire il moto tra alberi concorrenti con angoli abbastanza ampi. L'angolo acuto individuato dagli assi degli alberi di ingresso e di uscita del moto, è detto angolo del giunto. Principale caratteristica del giunto è quella di avere un rapporto di trasmissione variabile in maniera istantanea, quando l'angolo del giunto è diverso da zero. Il valore medio del rapporto di trasmissione si mantiene comunque unitario, per eliminare tale variabilità il collegamento viene realizzato impiegando un doppio giunto cardanico che realizza la condizione di uguaglianza tra le velocità angolari. La trasmissione del moto avviene attraverso un elemento che congiunge le estremità degli alberi di ingresso e di uscita. Tale elemento è detto crociera.

In generale la funzione di un cardano può essere divisa in 3 singole peculiarità:

- Coppia e velocità
- Possibilità di cambiare la distanza tra input e output
- Possibilità di cambiare angolo tra input e output.

A queste peculiarità vanno aggiunte sollecitazioni dovute a vibrazioni e forze torsionali aggiuntive. Una considerevole quantità d'energia data da queste condizioni d'uso estreme, viene assorbita in parte dal cardano e in parte dai componenti connessi ad esso. Per questi fattori viene richiesta ai cardani una elevata qualità. In modo da, allo stesso modo, risolvere facilmente ed economicamente molte applicazioni di trasmissione di potenza.

Le nostre trasmissioni cardaniche con una gamma di prodotti che va dalla serie XA alla XS, offrono un'eccellente sicurezza operativa, lunga vita di servizio e bassi costi di esercizio. Specialmente nel settore delle applicazioni pesanti e gravose, le nostre trasmissioni sono la corretta scelta per via delle seguenti caratteristiche costruttive:

- Forcella creata in un pezzo unico
- Maggiore angolatura e minima torsione sotto carichi elevati
- Maggiore capacità del cardano di sopportare elevati carichi di coppia
- Perfetta progettazione e realizzazione dei singoli componenti
- Materiali selezionati e trattamenti termici
- Saldature ottimali

Le nostre trasmissioni cardaniche sono costruite su misura secondo le richieste dei clienti. Per le serie XB abbiamo introdotto, ed adottato come standard dalla misura XB180 alla XB315, una nuova soluzione per le elevate velocità di rotazione. I nostri cardani sono saldati da professionisti che provvedono poi al test delle saldature con strumentazioni ad ultrasuoni ed alla bilanciatura dinamica secondo il grado G16 e lo standard DIN ISO 1940, a richiesta si eseguono bilanciature con un grado più accurato. In seguito vengono lubrificati secondo le eventuali richieste dei clienti ed al campo di applicazione a cui sono destinate, infine vengono verniciati. Siamo in grado di soddisfare ogni esigenza garantendo il miglior servizio, grazie alla flessibilità dei nostri processi di produzione, alla giacenza di componenti a magazzino ed alla capacità dei nostri impiegati. Il risultato finale sono cardani sempre di eccellente qualità.

*The Cardan Shaft owes its name to its eclectic inventor (Gerolamo Cardano, 1501 - 1576). A cardan shaft allows the transfer of motion between concurrent shafts through varying angles. The angle between the axes of the input and output shafts is said to be the deflection angle of the cardan shaft. The possibility to achieve deflection angles with cardan shafts is due its construction using drive elements including bearing mounted cross pieces mounted within drive yokes. These components are the at the heart of the transmission and their correct function and successful selection of a cardan shaft depends on the following transmission criteria:*

- Torque and speed
- Changing distance between power input and output
- Changing angle between power input and output.

*All this is permanently elapsed by shocks resulting in vibrations and additional torsion forces. Basing on these extreme conditions of operation considerable power is arising being consumed partly by the propshaft on its own, partly by the drive elements combining it. These high pressures and difficult operating conditions are demanding high standards to the driveshaft. At the same time, lots of power transmission applications are solved easily and costconsciously by the use of cardan shafts.*

*Our cardan shafts offer excellent operational safety, high service life and low running costs for an optimally adapted range of product series from XA to XS. Especially in the heavy duty field EPR Cardan shafts are the right choice for difficult and severe requirements due to the following construction features:*

- One piece yoke design
- Highest degree of strength and minimum distortion under load
- Perfect planning and realization of the single members
- Highest load capacity of the Universal Joint
- Suitable material selection and treatment
- Optimal weldings

*Our cardan shafts are tailor-made according to the individual requests of the customers. For XB series we have introduced a new solution for high speed rotations as standard from dimension XB180 up to XB315. The shafts welded by specialists will be checked with an ultrasonic test machine and dynamically balanced according to grade G 16 of the standard DIN ISO 1940, we can balance to sharper grades on demand. After that, they will be lubricated depending on the request of the customer and of the field of application and finally they will be painted. Owing to the flexibility during the process of manufacture, the corresponding stock-keeping, the commitment of the employees and the permanent customer orientation we are able to grant every customer the best service. The final result will be always best quality cardan shafts.*



*Spiritus hunc proptius veritatē, praecordia raris  
Docibus excolis, fidela clara morose.  
Nescio quid dicam, mirabori nil laetis illis,  
Quam legisse patres scribere plura solet.*



## 2. AZIENDA

## COMPANY

Leader dal 1976 nella commercializzazione di organi di trasmissione la E.P.R. si e' specializzata nella produzione di allunghe cardaniche.

I nostri prodotti sono largamente usati nel settore della laminazione, della gomma e plastica, della carta, della nautica, del sollevamento, della frantumazione, perforazione e minerario.

Vantiamo clienti in tutto il mondo con prevalenza in Italia e Medio Oriente. Ogni anno le nostre esportazioni aumentano per quantità e numero di paesi a cui sono dirette.

Il nostro obiettivo e' mantenere un livello qualitativo elevato e una totale soddisfazione della clientela, che ci impegniamo ad assicurare tramite la costante ricerca della perfezione dei nostri prodotti.

Alcuni punti del nostro programma di qualità sono:

- Operatività in certificazione ISO 9001:2000 per le attività commerciali e produttive.
- Un sistema gestionale che integra tutte le fasi dall'acquisizione di una richiesta da parte di un cliente, all'archiviazione dei dati, alla gestione delle giacenze alla spedizione del pezzo.
- I più avanzati strumenti di progettazione FEM e di disegno 2D e 3D AUTODESK™.
- Un team di persone proiettate verso un'obiettivo comune: garantire il miglior servizio possibile al cliente.
- I più moderni strumenti per il controllo dei processi di produzione e un costante rinnovo delle macchine utensili specifiche per la produzione di cardani della miglior qualità.

Tutte queste cose unite ai controlli ed ai test effettuati, ci permettono di proporre un servizio veloce e competitivo alle specifiche richieste della clientela, diventandone un punto di riferimento per la fornitura di cardani.

Il nostro impegno e' di mantenere la nostra posizione leader attraverso l'innovazione tecnica, il costante miglioramento della qualità e del servizio offerto.

*A leader in power transmissions since 1976, E.P.R. S.r.l. Company has specialized in manufacturing universal cardan shafts.*

*Our products are widely used in steel and aluminium rolling mills, rubber and plastic mills, paper mills, cranes, locomotives, marine craft , power plants, mining equipment to name only a few applications.*

*We have internationally renowned customers producing equipment installed in Italy and around the world. Exports of our cardan shafts are rising with deliveries to more countries and markets each year.*

*Our dedicated workforce has a goal to maintain the highest product quality and total customer satisfaction, constantly striving to improve manufacturing processes and implement the latest production techniques.*

*Highlights of our quality programs include:*

- *Manufacturing according to ISO 9001:2000 Quality Assurance System for commercial activities and production.*
- *A computer management system integrating planning, purchasing, sales, inventory and and costing programmes.*
- *An advanced design facility including FEM planning and design using 2D and 3D AUTODESK™.*
- *A competent engineering team and a dedicated highly skilled workforce.*
- *Modern production equipment including NC machine tools with custom programming for high quality universal joint shaft manufacturing.*

*Combined with a comprehensive inspection and testing process this equipment enables EPR to offer fast and competitive responses to the most demanding of customer requirements.*



### 3.PRODUZIONE

### PRODUCTION

Gli sforzi concentrati al perfezionamento del design e alle innovazioni tecniche ci permettono di produrre dei cardani con prestazioni e caratteristiche non comuni, con un livello qualitativo secondo a nessuno in Italia.

I punti di forza sono:

- Una maggiore vita dei cuscinetti:

Il nostro sistema di tenuta unico nel suo genere e il disegno autocentrante delle crociere garantisce una lubrificazione ottimale e di conseguenza una vita più lunga dei cuscinetti.

- Superiore precisione nelle lavorazioni:

La precisione degli alberi scanalati e dei tubi scorrevoli viene ottenuta tramite brocciatrici in un pezzo unico e dentatrici a creatore, per garantire la durata le superfici dentate vengono trattate con processi di nitrurazione.

- Qualità della bilanciatura:

I nostri cardani vengono assemblati con saldature poi controllate con strumenti ultrasonori (SONATEST PRISMA con Phased Array), attraverso studi sulle vibrazioni in seguito vengono di norma bilanciati dinamicamente conformemente al grado G16 delle norme DIN ISO 1940, tuttavia diversi gradi di bilanciatura sono disponibili a richiesta.

- Sistema anti-vibrazione:

Oltre alla bilanciatura è molto importante l'eliminazione del movimento che può generarsi dalla tolleranza tra le dentature di albero e tubo scorrevole. Tale movimento genera vibrazioni dannose per gli elementi collegati alle trasmissioni, per questo motivo abbiamo introdotto un sistema di guida al tubo di protezione che scorre con una tolleranza di 0,1mm come standard fino alla dimensione 315. Per ottenere questo risultato tutte le componenti devono essere perfettamente allineate all'asse centrale teorico del cardano. I vantaggi si riassumono in: tenuta allo sporco, assenza di vibrazioni e bilanciatura perfetta anche alle più elevate velocità di rotazione.

*Our continuing effort to achieve the best in design and technical innovation has enabled us to manufacture our universal joint and cardan shaft product line with outstanding features and performance at the highest quality level.*

*Our product strengths include:*

- *Prolonged Bearing Life:*

*Unique designs for bearing sealing and auto-centering of cross assemblies to ensure optimal lubricating conditions.*

- *Superior Machining Precision:*

*Spline sets are precision machined with a unique hobbing-broaching process. The spline surface are also hardened to ensure the accuracy and durability of the transmission is enhanced. The customer can choose between involute or rectangular tooth profiles for the splines.*

- *Optimal Balancing Quality:*

*Through research into vibration engineering, investment in state-of-the-art manufacturing technology and dynamic balancing techniques EPR has developed cardan shafts that work extremely well at high speeds. Furthermore, welded shafts are tested using Ultrasonic equipment (SONATEST PRISMA with Phased Array) and ensure the standard grade G16 DIN ISO1940 balancing level. Even high balancing grades are available on demand.*

- *Anti-vibration system:*

*In addition to the balancing has been very important the elimination of the movement that can be generated by the tolerance between the teeth of the shaft and sliding tube. This movement generates vibrations harmful to the elements connected to the transmission, for this reason we have introduced a system to guide the outer tube which runs with a tolerance of 0.1 mm as standard up to size 315. To achieve this result, all components must be perfectly aligned to the central theoretical axis of the cardan shaft. The advantages can be summarized as: keeping dirt, vibration and balance perfectly even at high speeds.*



Nuova strumentazione SONATEST PRISMA con Phased Array.  
New instrument SONATEST PRISMA with Phased Array.

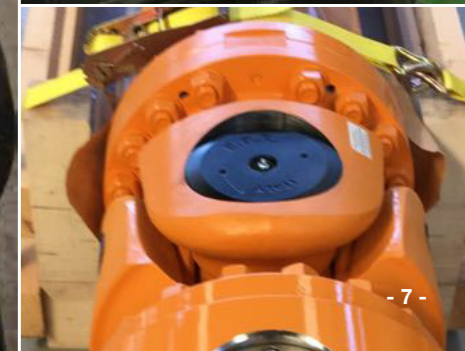
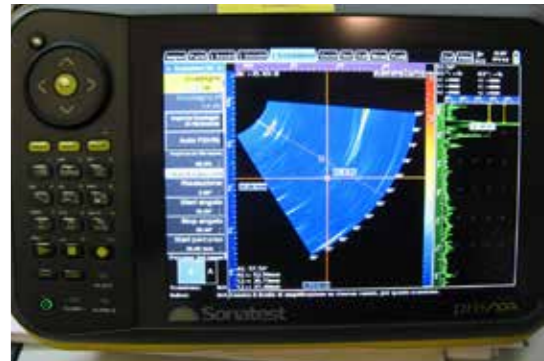

21. GIUNTI A DENTI SERIE XG

GEAR COUPLINGS XG SERIES

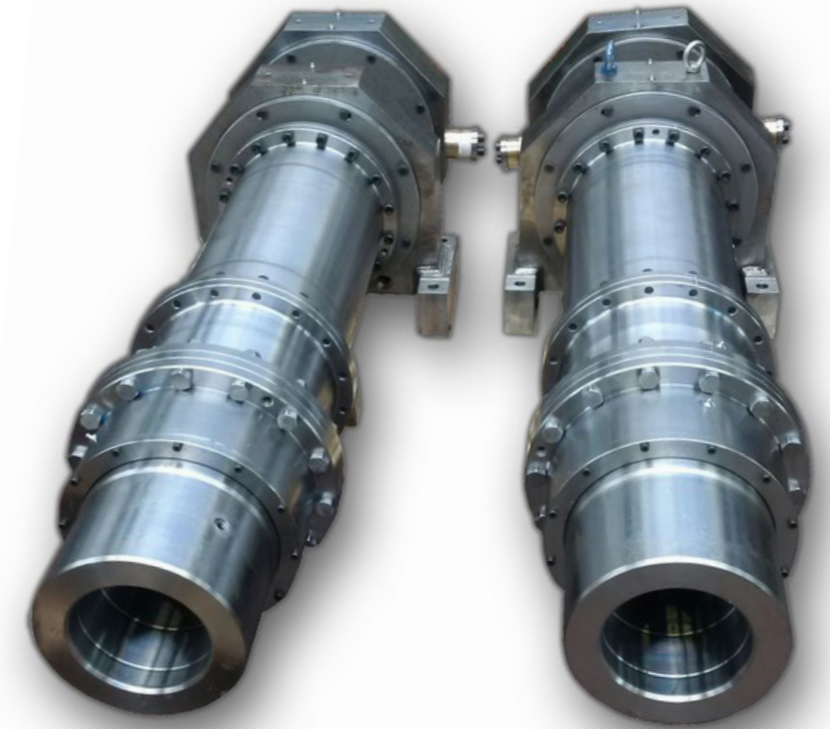

.... all'avanguardia della tecnologia, siamo specializzati in giunti speciali realizzati per le applicazioni piu' gravose

.... the vanguard of technology, we produce special gear couplings for heavy duty applications



# 21.1 GIUNTI A DENTI SERIE XG

Dal grande successo ottenuto con le nostre trasmissioni cardaniche nasce la nuova linea di giunti a denti EPR serie XG.

I giunti della serie XG sono costruiti e disponibili in acciaio bonificato AISI1045, AISI4140 oppure in acciaio inossidabile AISI630. Bulloni in classe 12.9, tappi ingrassatori in acciaio inox e guarnizioni o-ring in gomma NBR o in Viton.

Il principio di funzionamento dei giunti a denti, illustrato sinteticamente nella figura accanto si basa sull'ingranamento della dentatura esterna del mozzo con la dentatura interna del manicotto, o campana, che consente la trasmissione della coppia tra le flange. Il relativo disassamento viene compensato dallo scorrimento assiale della dentatura interna sulla dentatura esterna.

Mediante la dentatura bombata, i nostri giunti assicurano collegamenti ottimali e torsionalmente rigidi, tra i più diversi dispositivi, anche con moderati disallineamenti, spostamenti assiali e radiali.

Massimo disallineamento permesso dai giunti EPR:

- Serie Standard: 0°10'
- Con trattamento termico: 0°15'

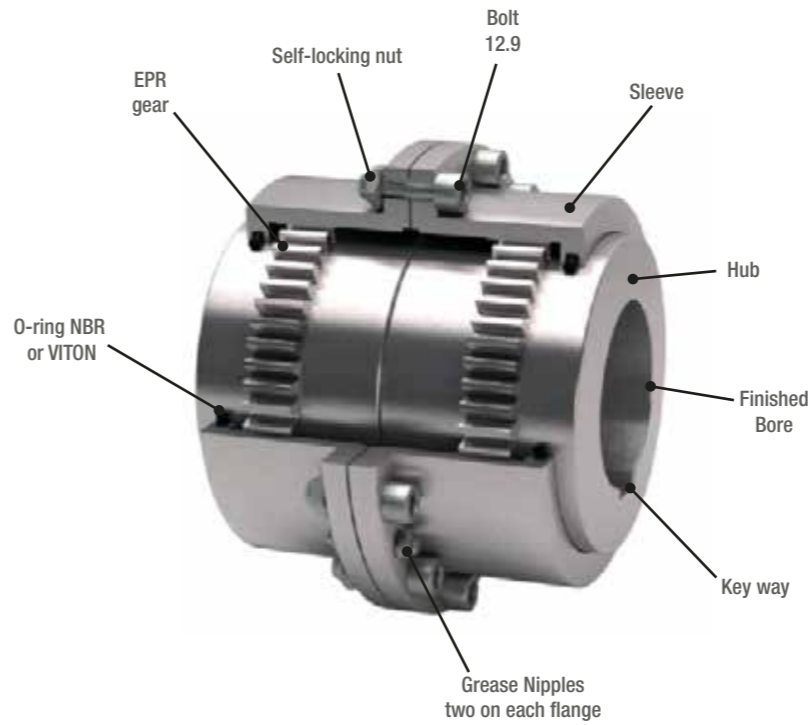
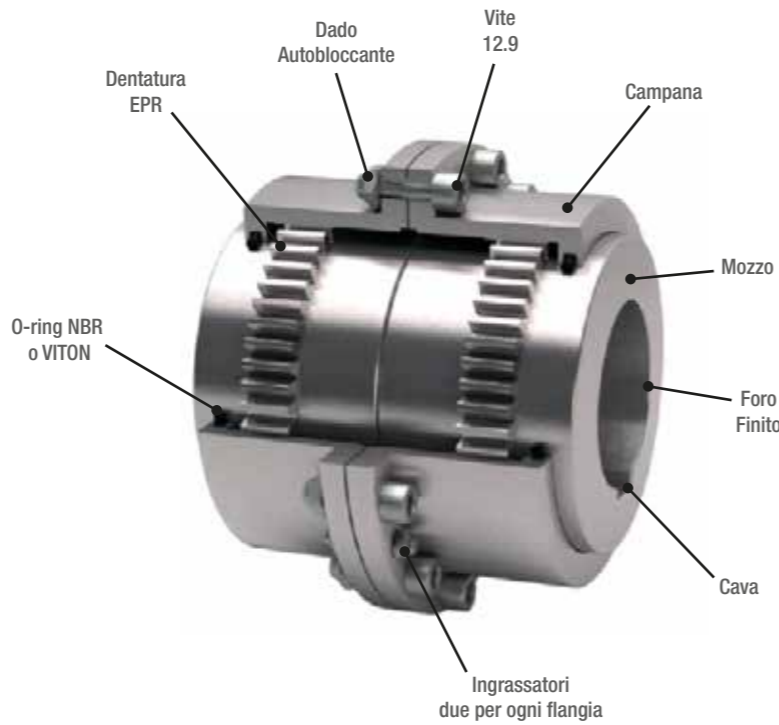

# GEAR COUPLINGS XG SERIES

From the large success obtained with our cardan transmissions is the new range of gear couplings EPR XG.

The joints of the XG series are manufactured and available hardened steel AISI1045, AISI4140 or stainless steel AISI630. Class 12.9 bolts, stainless steel grease caps and o-rings in rubber NBR or Viton.

The operating principle of the gear couplings synthetically illustrated in the figure beside relies on engagement of the external teeth of the hub with the internal toothing of the sleeve, or bell, which allows the transmission of torque between the flanges. The relative misalignment is compensated by axial sliding of the internal gear teeth on the external gear teeth.

Using the rounded gear, our joints ensure optimal connections and torsionally rigid, one of the most different devices, even with moderate misalignment, axial and radial.

Maximum allowed misalignment of the joints EPR:

- Standard series: 0°10'
- With heat treatment: 0°15'

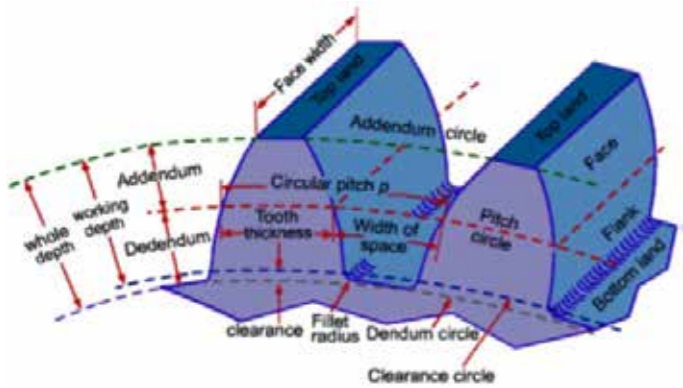

La dentatura bombata dei giunti a denti EPR serie XG, è stata progettata per assicurare condizioni di disallineamento su più estese superfici di contatto.

Lo scostamento del profilo utilizzato determina l'aumento dello spessore del dente e quindi la resistenza delle dentatura stessa.

The rounded gear of gear couplings EPR XG series, is designed to ensure conditions of misalignment of more extended surfaces of contact. The offset of the profile used determines the increase of the thickness of the tooth and therefore the resistance of the own gear.

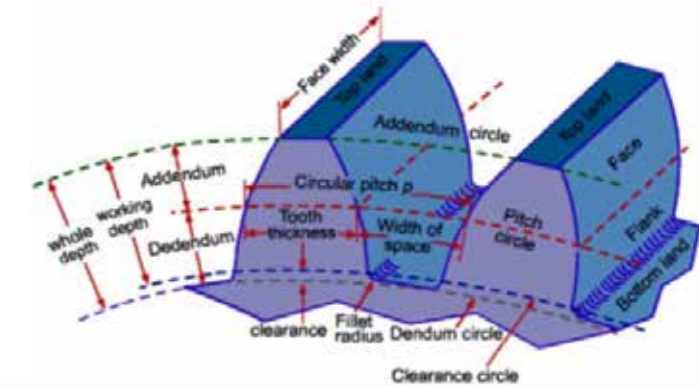

**21.2 GIUNTO A DENTI STANDARD - STANDARD GEAR COUPLING**

VALORI DI COPPIA TRASMISSIBILE - TRANSMISSIBLE TORQUE VALUES

SIZE	XG111	XG142	XG168	XG200	XG225	XG265	XG300	XG330	XG370	XG406	XG439	XG505
Tcs (KNm)	4.2	6.8	14.0	21.5	35.0	54.7	83.5	110	170	205	360	480
Tn (KNm)	1.9	2.9	5.7	9.0	14.5	22.8	34.8	45.8	70.8	85.4	150	200

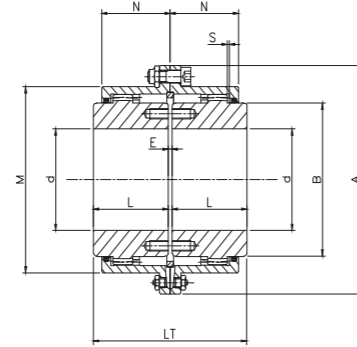
 TIPO - TYPE  
**XG<sub>xxx</sub>**

 $S=E/2$ 

DATI E DIMENSIONI - TECHNICAL DATA

TYPE SIZE	MAX SPEED [rpm]	d MAX [mm]	A [mm]	B [mm]	L [mm]	LT [mm]	M [mm]	N [mm]	E [mm]	WEIGHT [kg]
XG111	6000	52	111	68	43	89	82.5	39	3	4.2
XG142	4550	62	142	86	50	103	104.6	45.5	3	7.6
XG168	4000	78	168	105	62	127	130.5	59	3	13.5
XG200	3900	98	200	132	76	157	158.4	68	5	25
XG225	3700	112	225	151	90	185	183.4	82.5	5	37
XG265	3550	132	265	179	105	216	211.5	93	6	60
XG300	3000	156	300	209	120	246	245.5	106	6	90
XG330	2750	174	330	234	135	278	275	118	8	124
XG370	2420	190	370	255	150	308	307	138	8	170
XG406	2270	210	406	280	175	358	335	154	8	233
XG439	1950	233	439	306	190	388	367	166	8	298
XG505	1730	280	505	356	220	450	423	193	10	457

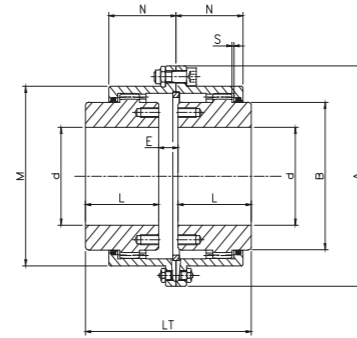
**21.3 GIUNTO A DENTI CON UN MOZZO INVERTITO - GEAR COUPLING WITH ONE HUB REVERSED**

 TIPO - TYPE  
**XG<sub>xxx.F</sub>**

 $S=E/2$ 

DATI E DIMENSIONI - TECHNICAL DATA

TYPE SIZE	MAX SPEED [rpm]	d MAX [mm]	A [mm]	B [mm]	L [mm]	LT [mm]	M [mm]	N [mm]	E [mm]	WEIGHT [kg]
XG111.F	6000	52	111	68	43	91	82.5	39	5	4.2
XG142.F	4550	62	142	86	50	108	104.6	45.5	8	7.6
XG168.F	4000	78	168	105	62	138	130.5	59	14	13.5
XG200.F	3900	98	200	132	76	170	158.4	68	18	25
XG225.F	3700	112	225	151	90	204	183.4	82.5	24	37
XG265.F	3550	132	265	179	105	237	211.5	93	27	60
XG300.F	3000	156	300	209	120	272	245.5	106	32	90
XG330.F	2750	174	330	234	135	307	275	118	37	124
XG370.F	2420	190	370	255	150	350	307	138	50	170
XG406.F	2270	210	406	280	175	403	335	154	53	233
XG439.F	1950	233	439	306	190	438	367	166	58	298
XG505.F	1730	280	505	356	220	512	423	193	72	457

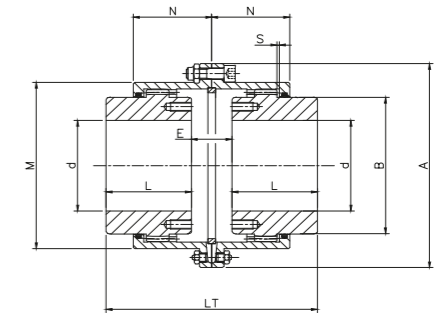
**21.4 GIUNTO A DENTI CON MOZZI INVERTITI - GEAR COUPLING WITH BOTH HUBS REVERSED**

 TIPO - TYPE  
**XG<sub>xxx.FF</sub>**

 $S=E/2$ 

DATI E DIMENSIONI - TECHNICAL DATA

TYPE SIZE	MAX SPEED [rpm]	d MAX [mm]	A [mm]	B [mm]	L [mm]	LT [mm]	M [mm]	N [mm]	E [mm]	WEIGHT [kg]
XG111.FF	6000	52	111	68	43	93	82.5	39	7	4.2
XG142.FF	4550	62	142	86	50	113	104.6	45.5	13	7.6
XG168.FF	4000	78	168	105	62	149	130.5	59	25	13.5
XG200.FF	3900	98	200	132	76	184	158.4	68	32	25
XG225.FF	3700	112	225	151	90	223	183.4	82.5	43	37
XG265.FF	3550	132	265	179	105	258	211.5	93	48	60
XG300.FF	3000	156	300	209	120	298	245.5	106	58	90
XG330.FF	2750	174	330	234	135	336	275	118	66	124
XG370.FF	2420	190	370	255	150	392	307	138	92	170
XG406.FF	2270	210	406	280	175	448	335	154	98	233
XG439.FF	1950	233	439	306	190	488	367	166	108	298
XG505.FF	1730	280	505	356	220	574	423	193	134	457

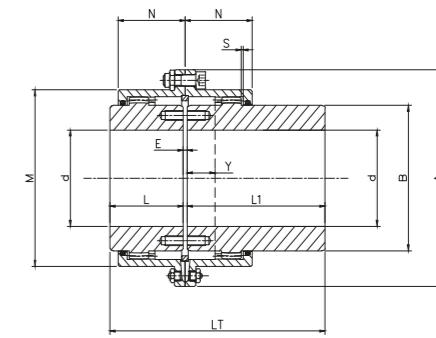
**21.5 GIUNTO A DENTI CON UN MOZZO PROLUNGATO - GEAR COUPLING WITH ONE EXTENDED HUB**

 TIPO - TYPE  
**XG<sub>xxx.N</sub>**

 $S=E/2$ 

DATI E DIMENSIONI - TECHNICAL DATA

TYPE SIZE	MAX SPEED [rpm]	d MAX [mm]	A [mm]	B [mm]	L [mm]	L1 [mm]	LT [mm]	M [mm]	N [mm]	Y [mm]	E [mm]	WEIGHT [kg]
XG111.N	6000	52	111	68	43	105	151	82.5	39	12	3	6.15
XG142.N	4550	62	142	86	50	115	168	104.6	45.5	16	3	10.2
XG168.N	4000	78	168	105	62	130	195	130.5	59	22	3	18.2
XG200.N	3900	98	200	132	76	150	231	158.4	68	26	5	33
XG225.N	3700	112	225	151	90	170	265	183.4	82.5	38	5	48.5
XG265.N	3550	132	265	179	105	185	296	211.5	93	45	6	56.5
XG300.N	3000	156	300	209	120	215	341	245.5	106	50	6	115
XG330.N	2750	174	330	234	135	245	388	275	118	58	8	161
XG370.N	2420	190	370	255	150	295	453	307	138	70	8	227
XG406.N	2270	210	406	280	175	300	483	335	154	80	8	292
XG439.N	1950	233	439	306	190	305	503	355	166	86	8	363
XG505.N	1730	280	505	356	220	310	540	423	193	96	10	526

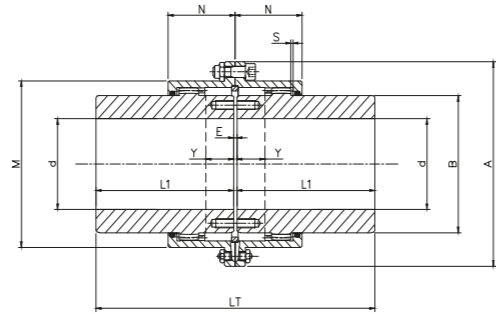

**21.6 GIUNTO A DENTI CON MOZZI PROLUNGATI - GEAR COUPLING WITH BOTH EXTENDED HUBS**

 TIPO - TYPE  
**XG<sub>xxx</sub>.NN**

**DATI E DIMENSIONI - TECHNICAL DATA**

TYPE SIZE	MAX SPEED [rpm]	d MAX [mm]	A [mm]	B [mm]	L1 [mm]	LT [mm]	M [mm]	N [mm]	Y [mm]	E [mm]	WEIGHT [kg]
XG111.NN	6000	52	111	68	105	213	82.5	39	12	3	8
XG142.NN	4550	62	142	86	115	233	104.6	45.5	16	3	13
XG168.NN	4000	78	168	105	130	263	130.5	59	22	3	23
XG200.NN	3900	98	200	132	150	305	158.4	68	26	5	41
XG225.NN	3700	112	225	151	170	345	183.4	82.5	38	5	60
XG265.NN	3550	132	265	179	185	376	211.5	93	45	6	91
XG300.NN	3000	156	300	209	215	436	245.5	106	50	6	141
XG330.NN	2750	174	330	234	245	498	275	118	58	8	199
XG370.NN	2420	190	370	255	295	598	307	138	70	8	285
XG406.NN	2270	210	406	280	300	608	335	154	80	8	352
XG439.NN	1950	233	439	306	305	618	355	166	86	8	428
XG505.NN	1730	280	505	356	310	630	423	193	96	10	596

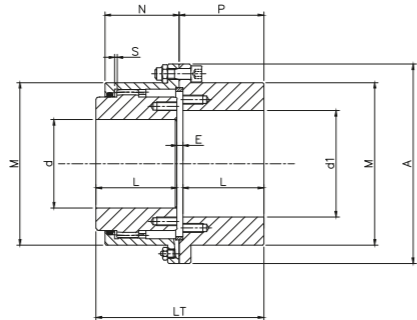
**21.7 GIUNTO A DENTI CON UN MOZZO RIGIDO - GEAR COUPLING WITH ONE FIXED HUB**

 TIPO - TYPE  
**XG<sub>xxx</sub>.E**

**DATI E DIMENSIONI - TECHNICAL DATA**

TYPE SIZE	MAX SPEED [rpm]	d MAX [mm]	d1 MAX [mm]	A [mm]	L [mm]	LT [mm]	M [mm]	N [mm]	P [mm]	E [mm]	WEIGHT [kg]
XG111.E	6000	52	60	111	43	89	82.5	39	44.5	3	4.5
XG142.E	4550	62	75	142	50	103	104.6	45.5	51.5	3	8
XG168.E	4000	78	90	168	62	127	130.5	59	63.5	3	14
XG200.E	3900	98	110	200	76	157	158.4	68	78.5	5	26
XG225.E	3700	112	130	225	90	185	183.4	82.5	92.5	5	39
XG265.E	3550	132	150	265	105	216	211.5	93	108	6	63
XG300.E	3000	156	175	300	120	246	245.5	106	123	6	95
XG330.E	2750	174	195	330	135	278	275	118	139	8	131
XG370.E	2420	190	220	370	150	308	307	138	154	8	180
XG406.E	2270	210	240	406	175	358	335	154	179	8	248
XG439.E	1950	233	260	439	190	388	367	166	194	8	318
XG505.E	1730	280	300	505	220	450	423	193	225	10	488

**21.8 GIUNTO A DENTI SERIE PESANTE - HEAVY DUTY GEAR COUPLING**

VALORI DI COPPIA TRASMISSIBILE - TRANSMISSIBLE TORQUE VALUES

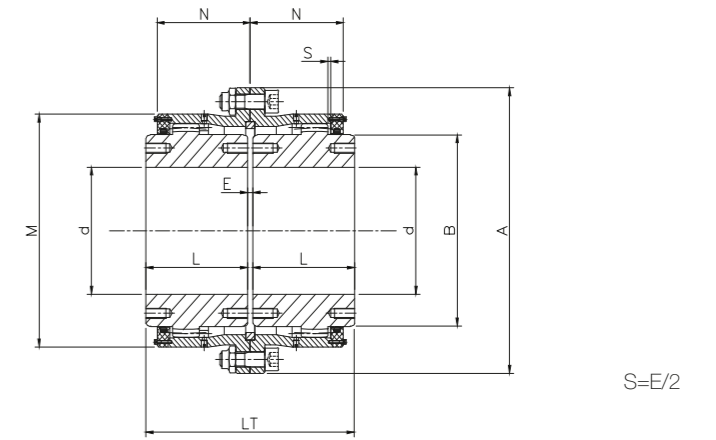
SIZE	XGH590	XGH639	XGH710	XGH769	XGH834	XGH894	XGH944	XGH1020	XGH1095	XGH1195	XGH1350	XGH1450	XGH1584	XGH1715	XGH1815	XGH1944
Tcs (KNm)	580	804	1036	1386	1764	2080	2510	3266	3812	5272	7414	9324	12432	15078	17850	22260
Tn (KNm)	290	402	518	693	882	1040	1255	1633	1906	2636	3707	4662	6216	7539	8925	11130

 TIPO - TYPE  
**XGH<sub>xxxx</sub>**

**DATI E DIMENSIONI - TECHNICAL DATA**

TYPE SIZE	MAX SPEED [rpm]	d MAX [mm]	A [mm]	B [mm]	L [mm]	LT [mm]	M [mm]	N [mm]	E [mm]	WEIGHT [kg]
XGH590	1100	325	590	410	260	532	503	221	12	722
XGH639	990	370	639	460	290	592	553	245	12	972
XGH710	890	400	710	500	320	652	597	262	12	1292
XGH769	785	430	769	560	350	712	657	280	12	1695
XGH834	700	475	834	620	380	772	722	292	12	2215
XGH894	645	510	894	660	400	820	763	315	20	2695
XGH944	600	530	944	690	420	860	813	327	20	3150
XGH1020	540	580	1020	760	440	900	888	346	20	3950
XGH1095	500	610	1095	800	480	990	938	385	30	4915
XGH1195	440	680	1195	880	530	1090	1038	414	30	6566
XGH1350	380	780	1350	1010	580	1190	1173	460	30	9420
XGH1450	330	860	1450	1110	630	1300	1273	507	40	12390
XGH1584	300	950	1584	1230	690	1420	1408	568	40	15904
XGH1715	280	1020	1715	1320	730	1500	1508	602	40	19631
XGH1815	250	1090	1815	1410	790	1620	1608	635	40	22543
XGH1944	230	1180	1944	1530	840	1730	1738	680	50	29572



**21.9 GIUNTO A DENTI CON DISCO FRENO - GEAR COUPLING WITH BRAKE DISC**

VALORI DI COPPIA TRASMISSIBILE - TRANSMISSIBLE TORQUE VALUES

SIZE	XG111	XG142	XG168	XG200	XG225	XG265	XG300	XG330	XG370	XG406	XG439	XG505
Tcs (KNm)	4.2	6.8	14.0	21.5	35.0	54.7	83.5	110	170	205	360	480
Tn (KNm)	1.9	2.9	5.7	9.0	14.5	22.8	34.8	45.8	70.8	85.4	150	200

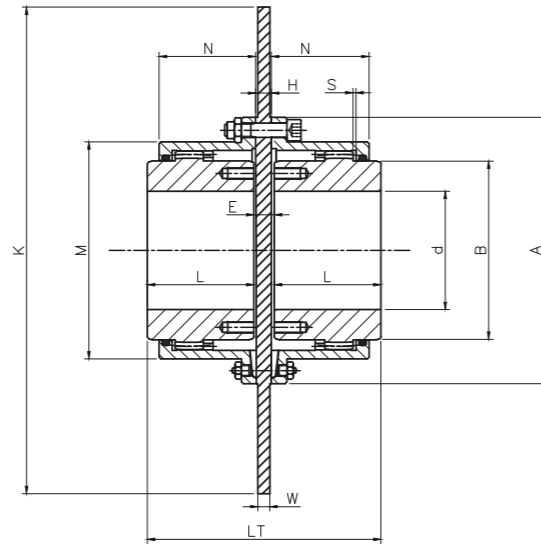
 TIPO - TYPE  
**XGxxx.VT**

DATI E DIMENSIONI - TECHNICAL DATA

TYPE SIZE	MAX SPEED [rpm]	d MAX [mm]	A [mm]	B [mm]	L [mm]	LT [mm]	M [mm]	N [mm]	E [mm]	K x H [mm]	Z [mm]	W [mm]
XG111.VT	6000	52	111	68	43	89	82.5	39	3+H	250x6	12.7	
XG142.VT	4550	62	142	86	50	103	104.6	45.5	3+H	300x13	12.7	
XG168.VT	4000	78	168	105	62	127	130.5	59	3+H	356x16	12.7	
XG200.VT	3900	98	200	132	76	157	158.4	68	5+H	406x13	12.7	
XG225.VT	3700	112	225	151	90	185	183.4	82.5	5+H	457x16	12.7	
XG265.VT	3550	132	265	179	105	216	211.5	93	6+H	514x16	12.7	
XG300.VT	3000	156	300	209	120	246	245.5	106	6+H	514x16	12.7	
XG330.VT	2750	174	330	234	135	278	275	118	8+H	610x16	12.7	
XG370.VT	2420	190	370	255	150	308	307	138	8+H	711x19	12.7	
XG406.VT	2270	210	406	280	175	358	335	154	8+H	762x25	25.4	
XG439.VT	1950	233	439	306	190	388	355	166	8+H	810x25	25.4	
XG505.VT	1730	280	505	356	220	450	423	193	10+H	914x25	25.4	

**21.10 GIUNTO A DENTI CON DISCO FRENO TIPO TWIFLEX - GEAR COUPLING WITH TWIFLEX BRAKE DISC**

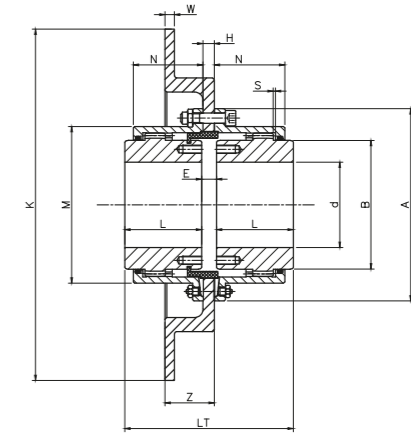
 TIPO - TYPE  
**XGxxx.TD**

DATI E DIMENSIONI - TECHNICAL DATA

TYPE SIZE	MAX SPEED [rpm]	d MAX [mm]	A [mm]	B [mm]	L [mm]	LT [mm]	M [mm]	N [mm]	E [mm]	K x H [mm]	Z [mm]	W [mm]
XG111.TD	6000	52	111	68	43	95	82.5	39	3+H	250x6	36	12.7
XG142.TD	4550	62	142	86	50	116	104.6	45.5	3+H	300x13	41	12.7
XG168.TD	4000	78	168	105	62	143	130.5	59	3+H	356x16	41	12.7
XG200.TD	3900	98	200	132	76	170	158.4	68	5+H	406x13	54	12.7
XG225.TD	3700	112	225	151	90	201	183.4	82.5	5+H	457x16	54	12.7
XG265.TD	3550	132	265	179	105	216	211.5	93	6+H	514x16	54	12.7
XG300.TD	3000	156	300	209	120	262	245.5	106	6+H	514x16	54	12.7
XG330.TD	2750	174	330	234	135	294	275	118	8+H	610x16	54	12.7
XG370.TD	2420	190	370	255	150	327	307	138	8+H	711x19	54	12.7
XG406.TD	2270	210	406	280	175	383	335	154	8+H	762x25	76	25.4
XG439.TD	1950	233	439	306	190	403	355	166	8+H	810x25	76	25.4
XG505.TD	1730	280	505	356	220	475	423	193	10+H	914x25	76	25.4

**21.11 GIUNTO A DENTI CON FASCIA FRENO - GEAR COUPLING WITH BRAKE**

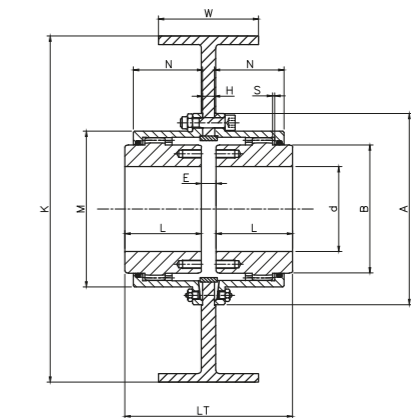
 TIPO - TYPE  
**XGxxx.VH**

DATI E DIMENSIONI - TECHNICAL DATA

TYPE SIZE	MAX SPEED [rpm]	d MAX [mm]	A [mm]	B [mm]	L [mm]	LT [mm]	M [mm]	N [mm]	E [mm]	K x H [mm]	Z [mm]	W [mm]
XG111.VH	6000	52	111	68	43	95	82.5	39	3+H	200x8	75	
XG142.VH	4550	62	142	86	50	116	104.6	45.5	3+H	200x8	75	
XG168.VH	4000	78	168	105	62	143	130.5	59	3+H	250x10	95	
XG200.VH	3900	98	200	132	76	170	158.4	68	5+H	250x10	95	
XG225.VH	3700	112	225	151	90	201	183.4	82.5	5+H	315x12	118	
XG265.VH	3550	132	265	179	105	216	211.5	93	6+H	400x14	150	
XG300.VH	3000	156	300	209	120	262	245.5	106	6+H	500x18	190	
XG330.VH	2750	174	330	234	135	294	275	118	8+H	500x18	190	
XG370.VH	2420	190	370	255	150	327	307	138	8+H	630x22	236	
XG406.VH	2270	210	406	280	175	383	335	154	8+H	630x22	236	
XG439.VH	1950	233	439	306	190	403	355	166	8+H	630x22	236	
XG505.VH	1730	280	505	356	220	475	423	193	10+H	710x22	265	



**21.12 GIUNTO A DENTI CON SPINE DI ROTTURA - GEAR COUPLING WITH SAFETY PINS**

VALORI DI COPPIA TRASMISSIBILE - TRANSMISSIBLE TORQUE VALUES

SIZE	XG111	XG142	XG168	XG200	XG225	XG265	XG300	XG330	XG370	XG406	XG439	XG505
Tcs (KNm)	4.2	6.8	14.0	21.5	35.0	54.7	83.5	110	170	205	360	480
Tn (KNm)	1.9	2.9	5.7	9.0	14.5	22.8	34.8	45.8	70.8	85.4	150	200

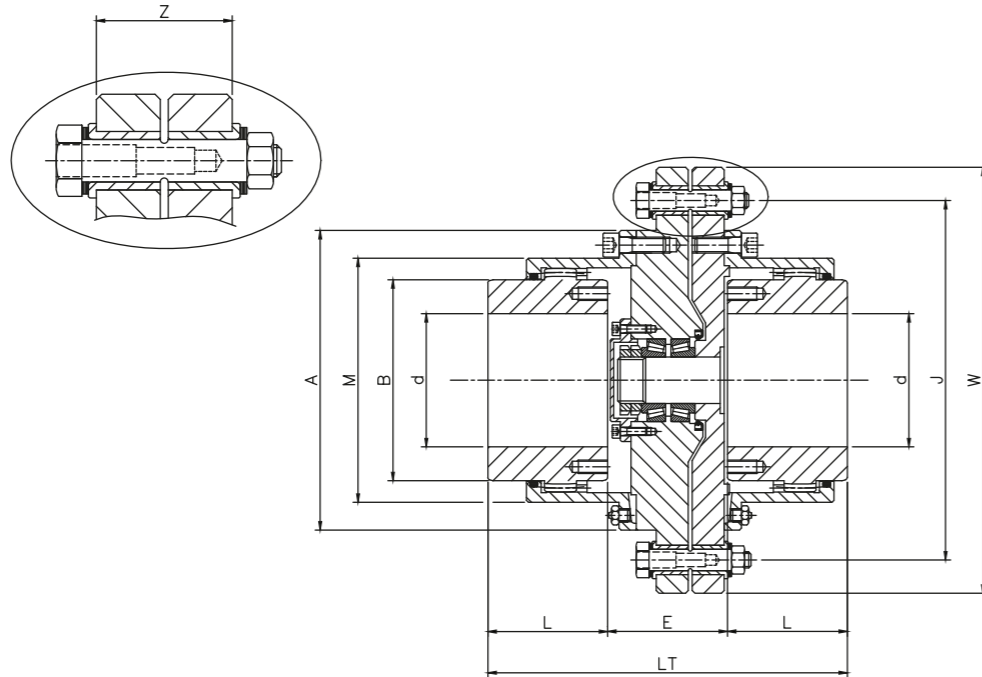
 TIPO - TYPE  
**XGxxx.ET**

 Dimensioni: W,J,Z,E su misura  
 Dimensions: W,J,Z,E CUSTOMIZED

DATI E DIMENSIONI - TECHNICAL DATA

TYPE SIZE	MAX SPEED [rpm]	d MAX [mm]	A [mm]	B [mm]	L [mm]	M [mm]	N [mm]
XG111.ET	6000	52	111	68	43	82.5	39
XG142.ET	4550	62	142	86	50	104.6	45.5
XG168.ET	4000	78	168	105	62	130.5	59
XG200.ET	3900	98	200	132	76	158.4	68
XG225.ET	3700	112	225	151	90	183.4	82.5
XG265.ET	3550	132	265	179	105	211.5	93
XG300.ET	3000	156	300	209	120	245.5	106
XG330.ET	2750	174	330	234	135	275	118
XG370.ET	2420	190	370	255	150	307	138
XG406.ET	2270	210	406	280	175	335	154
XG439.ET	1950	233	439	306	190	355	166
XG505.ET	1730	280	505	356	220	423	193

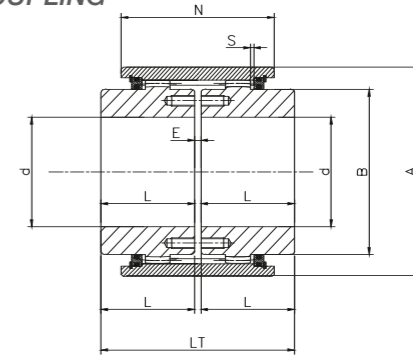
**21.13 GIUNTO A DENTI A MANICOTTO - SLEEVE GEAR COUPLING**

 TIPO - TYPE  
**XGxxx.CE**

DATI E DIMENSIONI - TECHNICAL DATA

TYPE SIZE	MAX SPEED [rpm]	d MAX [mm]	A [mm]	L [mm]	LT [mm]	B [mm]	N [mm]	E [mm]
XG111.CE	6000	52	88	43	89	68	63	3
XG142.CE	4550	62	108	50	103	86	74	3
XG168.CE	4000	78	133	62	127	105	89	3
XG200.CE	3900	98	163	76	157	132	102	5
XG225.CE	3700	112	188	90	185	151	108	5
XG265.CE	3550	132	213	105	216	179	118	6
XG300.CE	3000	156	248	120	246	209	130	6
XG330.CE	2750	174	278	135	278	234	138	8
XG370.CE	2420	190	313	150	308	255	156	8
XG406.CE	2270	210	338	175	358	280	152	8
XG439.CE	1950	233	368	190	388	306	160	8
XG505.CE	1730	280	423	220	450	356	180	10

**21.14 GIUNTO A DENTI SCORREVOLI - SLIDING GEAR COUPLING**

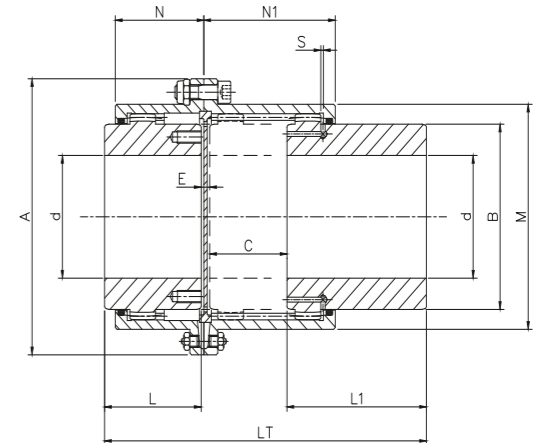
 TIPO - TYPE  
**XGxxx.EQ**

DATI E DIMENSIONI - TECHNICAL DATA

TYPE SIZE	MAX SPEED [rpm]	d MAX [mm]	A [mm]	B [mm]	L [mm]	L1 [mm]	N [mm]	LT [mm]	N1 [mm]	E [mm]	C [mm]
XG111.EQ	6000	52	111	68	43	100	39	212	92	7	62
XG142.EQ	4550	62	142	86	50	102	45.5	221	98	7	62
XG168.EQ	4000	78	168	105	62	110	59	243	106	7	64
XG200.EQ	3900	98	200	132	76	122	68	278	119	8	72
XG225.EQ	3700	112	225	151	90	130	82.5	300	122	8	72
XG265.EQ	3550	132	265	179	105	144	93	339	137	10	80
XG300.EQ	3000	156	300	209	120	156	106	374	151	10	88
XG330.EQ	2750	174	330	234	135	162	118	399	158	14	88
XG370.EQ	2420	190	370	255	150	180	13	446	181	14	102
XG406.EQ	2270	210	406	280	175	220	154	539	213	14	130
XG439.EQ	1950	233	439	306	190	220	166	554	217	14	130
XG505.EQ	1730	280	505	356	220	210	193	556	209	16	110

**21.15 GIUNTO A DENTI A DOPPIO SCORRIMENTO - DOUBLE SLIDING GEAR COUPLING**

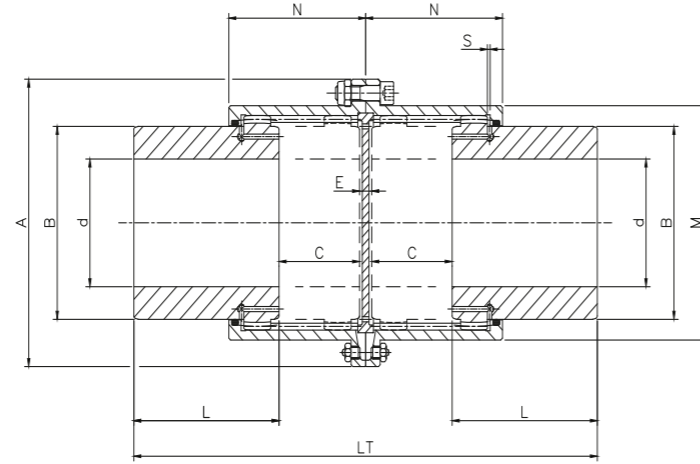
 TIPO - TYPE  
**XG<sub>xxx</sub>.EQQ**

**DATI E DIMENSIONI - TECHNICAL DATA**

TYPE SIZE	MAX SPEED [rpm]	d MAX [mm]	A [mm]	B [mm]	L [mm]	N [mm]	LT [mm]	N1 [mm]	E [mm]	2xC [mm]
XG111.EQQ	6000	52	111	68	100	92	235	92	11	124
XG142.EQQ	4550	62	142	86	102	98	339	98	11	124
XG168.EQQ	4000	78	168	105	110	106	359	106	11	128
XG200.EQQ	3900	98	200	132	122	119	399	119	11	144
XG225.EQQ	3700	112	225	151	130	122	415	122	11	144
XG265.EQQ	3550	132	265	179	144	137	462	137	14	160
XG300.EQQ	3000	156	300	209	156	151	502	151	14	176
XG330.EQQ	2750	174	330	234	162	158	520	158	20	176
XG370.EQQ	2420	190	370	255	180	181	584	181	20	204
XG406.EQQ	2270	210	406	280	220	213	720	213	20	260
XG439.EQQ	1950	233	439	306	220	217	720	217	20	260
XG505.EQQ	1730	280	505	356	210	209	662	209	22	220

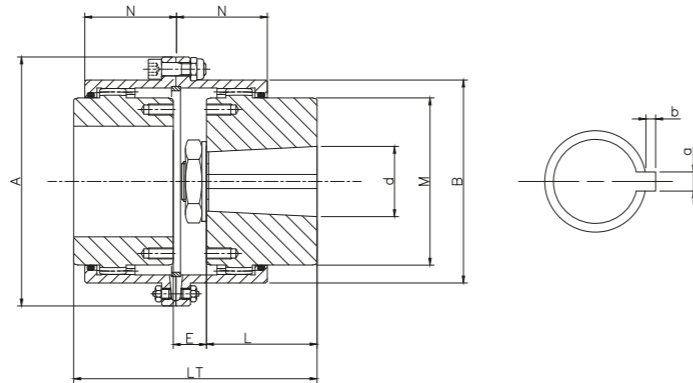
**21.16 GIUNTO A DENTI PER MOTORI MILL - GEAR COUPLING FOR MILL MOTORS**

 TIPO - TYPE  
**XG<sub>xxx</sub>.MM**

**DATI E DIMENSIONI - TECHNICAL DATA**

TYPE SIZE	MAX SPEED [rpm]	d MAX [mm]	A [mm]	B [mm]	L [mm]	LT [mm]	N [mm]	E [mm]
XG111.MM	6000	52	111	68	105	151	39	28
XG142.MM	4550	62	142	86	115	168	45.5	30
XG168.MM	4000	78	168	105	130	195	59	30
XG200.MM	3900	98	200	132	150	231	68	35
XG225.MM	3700	112	225	151	170	265	82.5	41
XG265.MM	3550	132	265	179	185	296	93	46
XG300.MM	3000	156	300	209	215	296	106	52
XG330.MM	2750	174	330	234	245	341	118	54
XG370.MM	2420	190	370	255	295	388	138	70
XG406.MM	2270	210	406	280	300	453	154	70
XG439.MM	1950	233	439	306	305	483	166	70

**21.17 GIUNTO A DENTI DISINNESTABILI - GEAR COUPLING DISENGAGEABLE**

VALORI DI COPPIA TRASMISSIBILE - TRANSMISSIBLE TORQUE VALUES

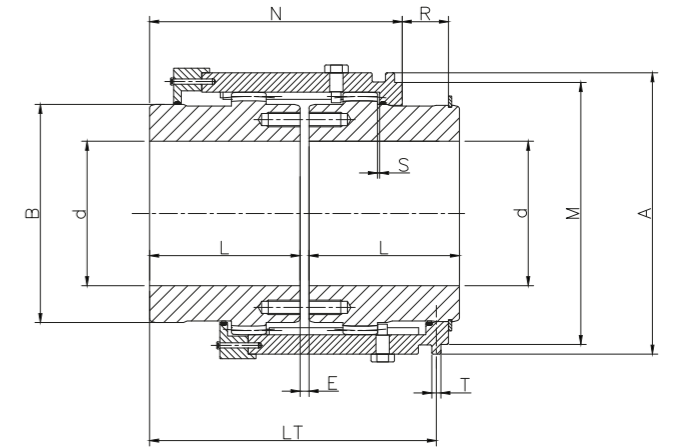
SIZE	XG98	XG118	XG150	XG173	XG198	XG228	XG258	XG288	XG318	XG348	XG393	XG448
Tcs (KNm)	4.55	7	14	22	35.5	57.4	87.7	111.1	176.3	211.7	384	513
Tn (KNm)	1.9	2.9	5.85	9.15	14.8	23.9	36.5	46.3	73.5	88.2	160	213.5

 TIPO - TYPE  
**XG<sub>xxx</sub>.TO**

**DATI E DIMENSIONI - TECHNICAL DATA**

TYPE SIZE	MAX SPEED [rpm]	d MAX [mm]	A [mm]	B [mm]	L [mm]	N [mm]	LT [mm]	N1 [mm]	E [mm]	T [mm]	M [mm]	R [mm]
XG98.TO	3000	52	98	68	60	98	112	92	3	6	90	17
XG118.TO	2500	62	118	86	70	111	124	98	3	6	110	22
XG150.TO	2000	78	150	105	85	135.5	152.5	106	3	8	138	29
XG173.TO	1800	98	173	132	95	155.5	176	119	5	8	161	32
XG198.TO	1500	112	198	151	105	170.5	192.5	122	5	8	186	34
XG228.TO	1350	132	228	179	120	195	220	137	6	12	215	39
XG258.TO	1200	156	258	209	130	206	235	151	6	12	248	45
XG288.TO	1100	174	288	234	150	238	272	158	8	12	273	50
XG318.TO	950	190	318	255	175	279	319	181	8	12	300	56
XG348.TO	900	210	348	280	190	303	348	213	8	12	329	62
XG393.TO	800	233	393	306	220	356	407	217	8	12	374	70
XG448.TO	700	280	448	356	250	404	461	209	10	16	356	77



21.18 GIUNTO A DENTI CON SPAZIATORE TUBOLARE - GEAR COUPLING WITH SPACER TUBE

VALORI DI COPPIA TRASMISSIBILE - TRANSMISSIBLE TORQUE VALUES

SIZE	XGS111	XGS142	XGS168	XGS200	XGS225	XGS265	XGS300	XGS330	XGS370	XGS406	XGS439	XGS505
Tcs (KNm)	4.2	6.8	14.0	21.5	35.0	54.7	83.5	110	170	205	360	480
Tn (KNm)	1.9	2.9	5.7	9.0	14.5	22.8	34.8	45.8	70.8	85.4	150	200

TIPO - TYPE

XGSxxx.D

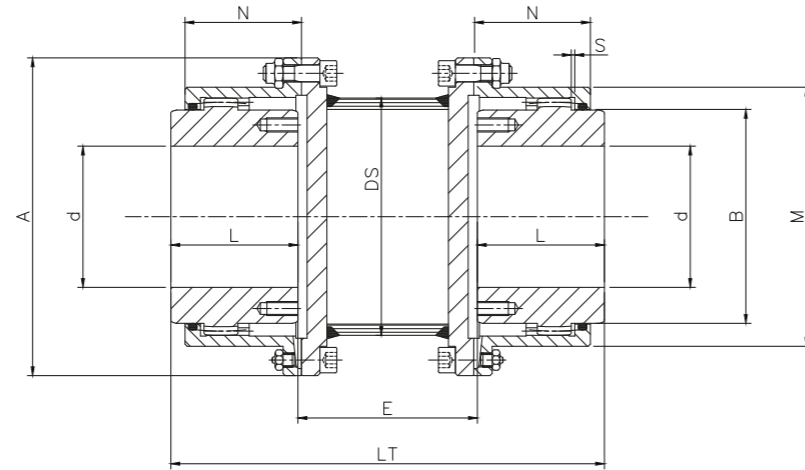

DATI E DIMENSIONI - TECHNICAL DATA

TYPE SIZE	MAX SPEED (rpm)	d MAX (mm)	A [mm]	B [mm]	L [mm]	LT [mm]	M [mm]	N [mm]	DS[mm]
XGS111.D	6000	52	111	68	43	105	82.5	39	82.5
XGS142.D	4550	62	142	86	50	115	104.6	45.5	88.9
XGS168.D	4000	78	168	105	62	130	130.5	59	127
XGS200.D	3900	98	200	132	76	150	158.4	68	139
XGS225.D	3700	112	225	151	90	170	183.4	82.5	168
XGS265.D	3550	132	265	179	105	185	211.5	93	168
XGS300.D	3000	156	300	209	120	215	245.5	106	219
XGS330.D	2750	174	330	234	135	245	275	118	273
XGS370.D	2420	190	370	255	150	295	307	138	273
XGS406.D	2270	210	406	280	175	300	335	154	324
XGS439.D	1950	233	439	306	190	305	355	166	355
XGS505.D	1730	280	505	356	220	310	423	193	406

21.19 GIUNTO A DENTI CON SPAZIATORE TUBOLARE E MOZZO PROLUNGATO  
GEAR COUPLING WITH SPACER TUBE AND ONE EXTENDED HUB

TIPO - TYPE

XGSxxx.DN

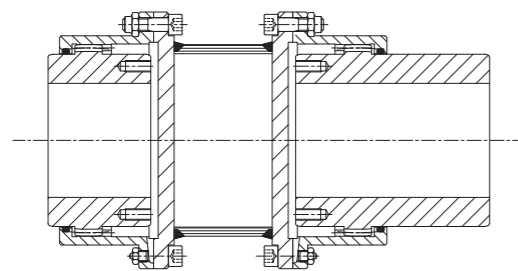

21.20 GIUNTO A DENTI CON SPAZIATORE TUBOLARE E MOZZI PROLUNGATI  
GEAR COUPLING WITH SPACER TUBE AND TWO EXTENDED HUBS

TIPO - TYPE

XGSxxx.DNN

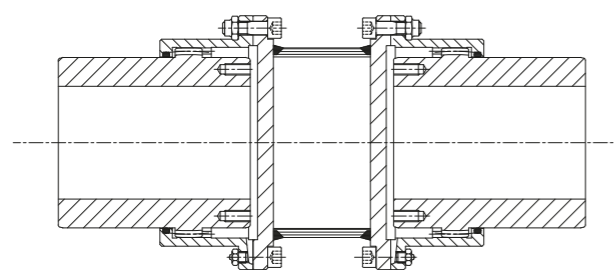

21.21 GIUNTO A DENTI CON SPAZIATORE TUBOLARE E MOZZO INVERTITO  
GEAR COUPLING WITH SPACER TUBE AND ONE REVERSED HUB

TIPO - TYPE

XGSxxx.DF

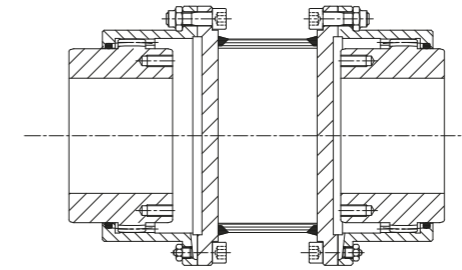

21.22 GIUNTO A DENTI CON SPAZIATORE TUBOLARE E MOZZI INVERTITI  
GEAR COUPLING WITH SPACER TUBE AND TWO REVERSED HUBS

TIPO - TYPE

XGSxxx.DFF

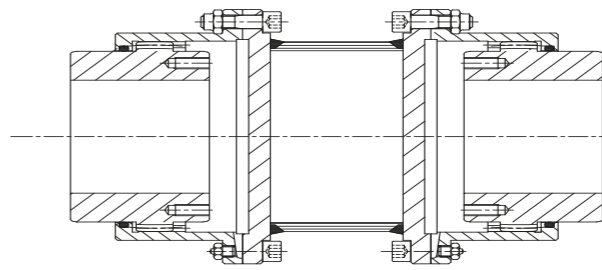

21.23 GIUNTO A DENTI CON ALBERO FLOTTANTE INTERMEDIO  
GEAR COUPLING WITH INTERMEDIATE FLOATING SHAFT

VALORI DI COPPIA TRASMISSIBILE - TRANSMISSIBLE TORQUE VALUES

SIZE	XGS111	XGS142	XGS168	XGS200	XGS225	XGS265	XGS300	XGS330	XGS370	XGS406	XGS439	XGS505
Tcs (KNm)	4.2	6.8	14.0	21.5	35.0	54.7	83.5	110	170	205	360	480
Tn (KNm)	1.9	2.9	5.7	9.0	14.5	22.8	34.8	45.8	70.8	85.4	150	200

TIPO - TYPE

XGSxxx.E

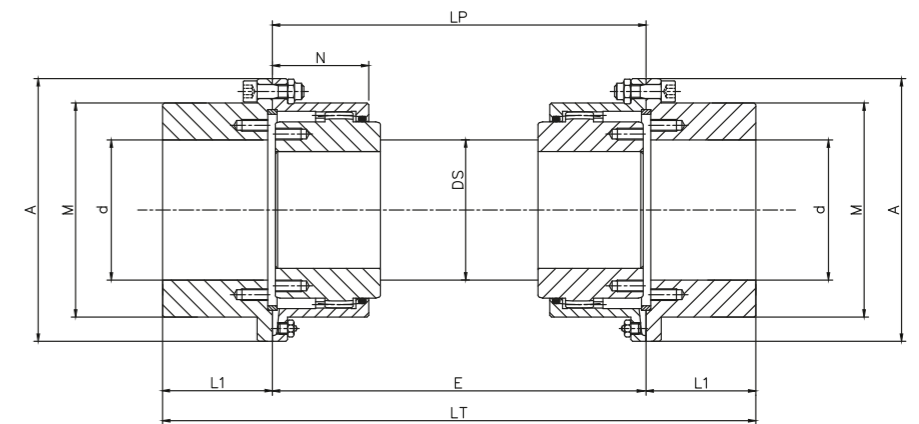

DATI E DIMENSIONI - TECHNICAL DATA

TYPE SIZE	MAX SPEED (rpm)	d MAX (mm)	A [mm]	B [mm]	L1 [mm]	M [mm]	N [mm]	DS[mm]
XGS111.E	6000	52	111	68	43	82.5	39	55
XGS142.E	4550	62	142	86	50	104.6	45.5	65
XGS168.E	4000	78	168	105	62	130.5	59	80
XGS200.E	3900	98	200	132	76	158.4	68	100
XGS225.E	3700	112	225	151	90	183.4	82.5	115
XGS265.E	3550	132	265	179	105	211.5	93	135
XGS300.E	3000	156	300	209	120	245.5	106	160
XGS330.E	2750	174	330	234	135	275	118	180
XGS370.E	2420	190	370	255	150	307	138	195
XGS406.E	2270	210	406	280	175	335	154	215
XGS439.E	1950	233	439	306	190	367	166	235
XGS505.E	1730	280	505	356	220	423	193	285

**21.24 GIUNTO A DENTI CON ALBERO FLOTTANTE INTERMEDIO E MOZZI INVERTITI**  
**GEAR COUPLING WITH INTERMEDIATE FLOATING SHAFT AND REVERSED HUBS**

VALORI DI COPPIA TRASMISSIBILE - TRANSMISSIBLE TORQUE VALUES

TIPO - TYPE

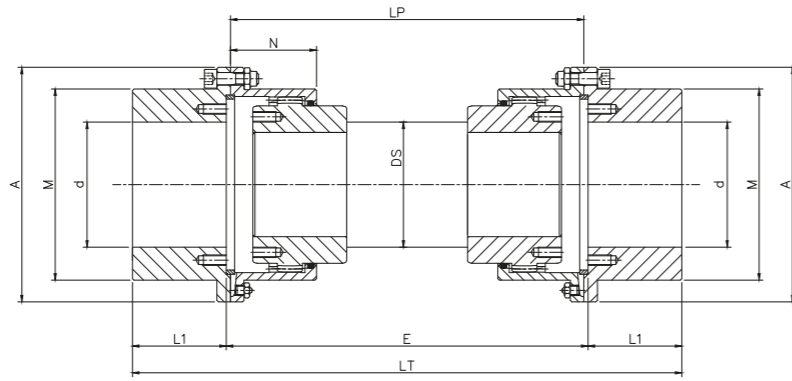
**XGS<sub>xxx</sub>.EF**

DATI E DIMENSIONI - TECHNICAL DATA

TYPE SIZE	MAX SPEED [rpm]	d MAX [mm]	A [mm]	B [mm]	L1 [mm]	M [mm]	N [mm]	DS[mm]
XGS111.EF	6000	52	111	68	43	82.5	39	55
XGS142.EF	4550	62	142	86	50	104.6	45.5	65
XGS168.EF	4000	78	168	105	62	130.5	59	80
XGS200.EF	3900	98	200	132	76	158.4	68	100
XGS225.EF	3700	112	225	151	90	183.4	82.5	115
XGS265.EF	3550	132	265	179	105	211.5	93	135
XGS300.EF	3000	156	300	209	120	245.5	106	160
XGS330.EF	2750	174	330	234	135	275	118	180
XGS370.EF	2420	190	370	255	150	307	138	195
XGS406.EF	2270	210	406	280	175	335	154	215
XGS439.EF	1950	233	439	306	190	367	166	235
XGS505.EF	1730	280	505	356	220	423	193	285

**21.25 GIUNTO A DENTI CON ISOLAMENTO ELETTRICO - GEAR COUPLING WITH ELECTRICAL INSULATION**

TIPO - TYPE

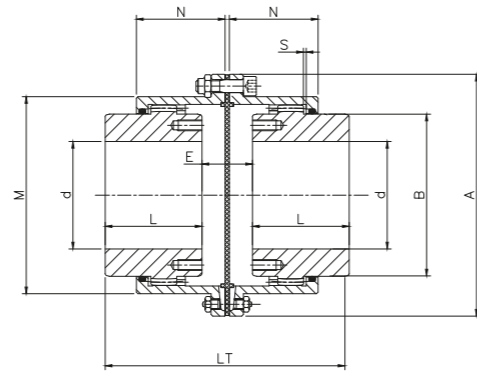
**XG<sub>xxx</sub>.SO**

DATI E DIMENSIONI - TECHNICAL DATA

TYPE SIZE	MAX SPEED [rpm]	d MAX [mm]	A [mm]	B [mm]	L [mm]	LT [mm]	M [mm]	N [mm]	E [mm]
XG111.SO	6000	52	111	68	43	93	82.5	39	10
XG142.SO	4550	62	142	86	50	113	104.6	45.5	16
XG168.SO	4000	78	168	105	62	149	130.5	59	28
XG200.SO	3900	98	200	132	76	184	158.4	68	42
XG225.SO	3700	112	225	151	90	223	183.4	82.5	47
XG265.SO	3550	132	265	179	105	258	211.5	93	52
XG300.SO	3000	156	300	209	120	298	245.5	106	63
XG330.SO	2750	174	330	234	135	336	275	118	71
XG370.SO	2420	190	370	255	150	392	307	138	97
XG406.SO	2270	210	406	280	175	448	335	154	103
XG439.SO	1950	233	439	306	190	488	367	166	113
XG505.SO	1730	280	505	356	220	574	423	193	139

**21.26 GIUNTO A DENTI PER MONTAGGIO VERTICALE - GEAR COUPLING FOR VERTICAL APPLICATION**

TIPO - TYPE

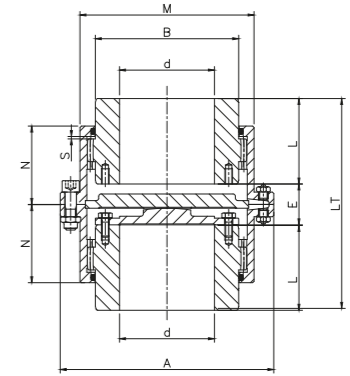
**XG<sub>xxx</sub>.B**

DATI E DIMENSIONI - TECHNICAL DATA

TYPE SIZE	MAX SPEED [rpm]	d MAX [mm]	A [mm]	B [mm]	L [mm]	LT [mm]	M [mm]	N [mm]	E [mm]
XG111.B	6000	52	111	68	43	109	82.5	39	23
XG142.B	4550	62	142	86	50	123	104.6	45.5	23
XG168.B	4000	78	168	105	62	155	130.5	59	31
XG200.B	3900	98	200	132	76	183	158.4	68	31
XG225.B	3700	112	225	151	90	223	183.4	82.5	43
XG265.B	3550	132	265	179	105	258	211.5	93	48
XG300.B	3000	156	300	209	120	298	245.5	106	58
XG330.B	2750	174	330	234	135	336	275	118	66
XG370.B	2420	190	370	255	150	392	307	138	92
XG406.B	2270	210	406	280	175	448	335	154	98
XG439.B	1950	233	439	306	190	488	367	166	108
XG505.B	1730	280	505	356	220	450	423	193	134

**21.27 GIUNTO A DENTI CON SPAZIATORE TUBOLARE PER MONTAGGIO VERTICALE**  
**GEAR COUPLING WITH SPACER FOR VERTICAL APPLICATION**

TIPO - TYPE

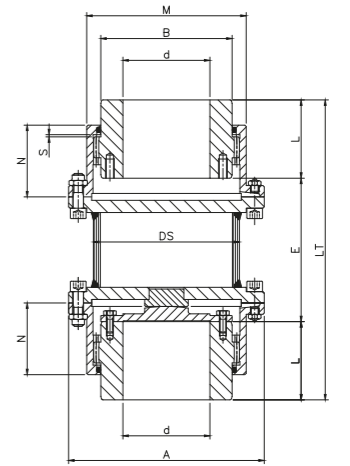
**XGS<sub>xxx</sub>.DB**

DATI E DIMENSIONI - TECHNICAL DATA

TYPE SIZE	MAX SPEED [rpm]	d MAX [mm]	A [mm]	B [mm]	L [mm]	M [mm]	N [mm]	DS[mm]
XGS111.DB	6000	52	111	68	43	82.5	39	82.5
XGS142.DB	4550	62	142	86	50	104.6	45.5	88.9
XGS168.DB	4000	78	168	105	62	130.5	59	127
XGS200.DB	3900	98	200	132	76	158.4	68	139
XGS225.DB	3700	112	225	151	90	183.4	82.5	168
XGS265.DB	3550	132	265	179	105	211.5	93	168
XGS300.DB	3000	156	300	209	120	245.5	106	219
XGS330.DB	2750	174	330	234	135	275	118	273
XGS370.DB	2420	190	370	255	150	307	138	273
XGS406.DB	2270	210	406	280	175	335	154	324
XGS439.DB	1950	233	439	306	190	367	166	355
XGS505.DB	1730	280	505	356	220	423	193	406

**21.28 GIUNTO A DENTI CON GUARNIZIONI IN FELTRO - GEAR COUPLING WITH FELT SEALS**

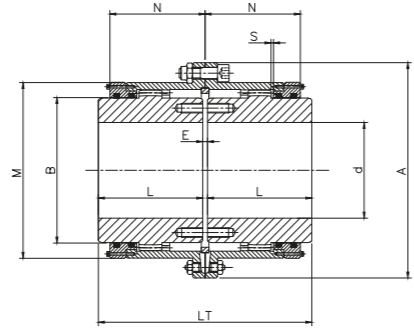
 TIPO - TYPE  
**XG<sub>xxx</sub>.RS**

**DATI E DIMENSIONI - TECHNICAL DATA**

TYPE SIZE	MAX SPEED [rpm]	d MAX [mm]	A [mm]	B [mm]	L [mm]	LT [mm]	M [mm]	N [mm]	E [mm]
XG111.SR	6000	52	111	68	43	93	82.5	39	10
XG142.SR	4550	62	142	86	50	113	104.6	45.5	16
XG168.SR	4000	78	168	105	62	149	130.5	59	28
XG200.SR	3900	98	200	132	76	184	158.4	68	42
XG225.SR	3700	112	225	151	90	223	183.4	82.5	47
XG265.SR	3550	132	265	179	105	258	211.5	93	52
XG300.SR	3000	156	300	209	120	298	245.5	106	63
XG330.SR	2750	174	330	234	135	336	275	118	71
XG370.SR	2420	190	370	255	150	392	307	138	97
XG406.SR	2270	210	406	280	175	448	335	154	103
XG439.SR	1950	233	439	306	190	488	367	166	113
XG505.SR	1730	280	505	356	220	574	423	193	139

**21.29 GIUNTO A DENTI IN ACCIAIO INOSSIDABILE - STAINLESS STEEL GEAR COUPLING**
**VALORI DI COPPIA TRASMISSIBILE - TRANSMISSIBLE TORQUE VALUES**

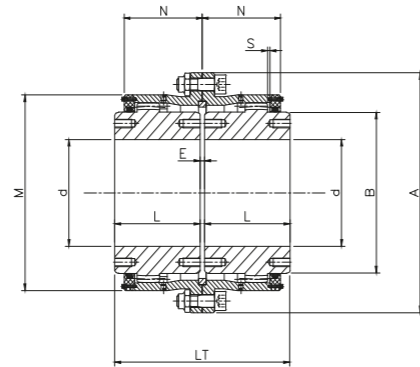
SIZE	XG111	XG142	XG168	XG200	XG225	XG265	XG300	XG330	XG370	XG406	XG439	XG505
Tcs (KNm)	7.2	11.2	22	36	54	86	148	218	266	430	530	660
Tn (KNm)	3.6	5.6	11	18	27	43	74	109	133	215	265	330

 TIPO - TYPE  
**XG<sub>xxxx</sub>.EE**

S=E/2

**DATI E DIMENSIONI - TECHNICAL DATA**

TYPE SIZE	MAX SPEED [rpm]	d MAX [mm]	A [mm]	B [mm]	L [mm]	LT [mm]	M [mm]	N [mm]	E [mm]
XG111.EE	6000	52	111	68	43	89	82.5	39	3
XG142.EE	4550	62	142	86	50	103	104.6	45.5	3
XG168.EE	4000	78	168	105	62	127	130.5	59	3
XG200.EE	3900	98	200	132	76	157	158.4	68	5
XG225.EE	3700	112	225	151	90	185	183.4	82.5	5
XG265.EE	3550	132	265	179	105	216	211.5	93	6
XG300.EE	3000	156	300	209	120	246	245.5	106	6
XG330.EE	2750	174	330	234	135	278	275	118	8
XG370.EE	2420	190	370	255	150	308	307	138	8
XG406.EE	2270	210	406	280	175	358	335	154	8
XG439.EE	1950	233	439	306	190	388	367	166	8
XG505.EE	1730	280	505	356	220	450	423	193	10

**21.30 GIUNTO A DENTI SERIE AGMA - AGMA GEAR COUPLING SERIES**
**VALORI DI COPPIA TRASMISSIBILE - TRANSMISSIBLE TORQUE VALUES**

SIZE	XGA1	XGA1.5	XGA2	XGA2.5	XGA3	XGA3.5	XGA4	XGA4.5	XGA5	XGA5.5	XGA6	XGA7
Tn (KNm)	1.0	2.2	4.1	7.1	11	17.2	25	35.1	51.2	78.1	89.8	135.2
Tn (lb-in)	8.85	19.40	36.20	62.80	97.30	152.20	221.20	310.60	453.10	691.20	794.80	1196.60

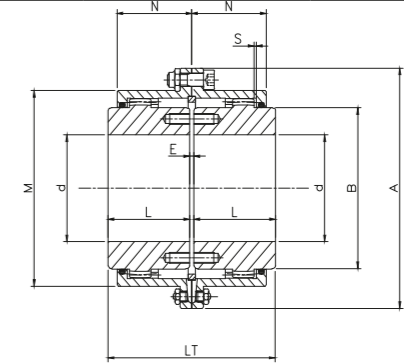
 TIPO - TYPE  
**XGA<sub>x</sub>**

S=E/2

**DATI E DIMENSIONI - TECHNICAL DATA**

TYPE SIZE	MAX SPEED [rpm]	d MAX [in]	A [in]	M [in]	N [in]	LT [in]	B [in]	E [in]
XGA1	6200	1.65	4.56	3.06	1.66	3.50	2.31	0.13
XGA1.5	5700	2.2	6.00	3.97	1.88	4.00	3	0.13
XGA2	5100	2.75	7.00	4.86	2.38	5.00	4	0.13
XGA2.5	4450	3.35	8.38	5.84	2.88	6.25	4.63	0.19
XGA3	4100	4.21	9.44	6.84	3.31	7.38	5.63	0.19
XGA3.5	3550	4.92	11.00	7.91	3.81	8.63	6.50	0.25
XGA4	3100	5.5	12.50	9.25	4.25	9.75	7.50	0.25
XGA4.5	2750	6.3	13.63	1.38	4.81	10.94	8.50	0.31
XGA5	2550	6.7	15.31	11.56	5.50	12.38	9.50	0.31
XGA5.5	2250	7.75	16.75	12.72	6.00	14.13	10.50	0.31
XGA6	2100	8.4	18.00	14.00	6.69	15.13	11.50	0.31
XGA7	2000	10	20.75	15.75	7.38	17.75	13.00	0.38

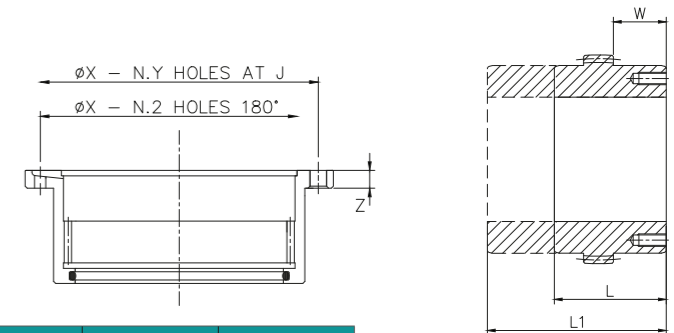
**GIUNTI A DENTI SERIE AGMA**
**DETTAGLIO COMPONENTI: MOZZI E CAMPANE  
 AGMA GEAR COUPLINGS SERIES COMPONENTS:  
 HUBS & SLEEVES DETAILS**

TYPE SIZE	INTERASSE FORATURA "X" Distance between hole centers "X"	BULLONI - bolts		Z [in]	L [in]	L1 [in]	W [in]
		Q.TA' - q.ty	DIM. - size				
XGA1	3.75	6	1/4	0.52	1.69	4	0.75
XGA1.5	4.812	8	3/8	0.76	1.94	4.5	0.81
XGA2	5.875	6	1/2	0.76	2.44	4.5	1.25
XGA2.5	7.125	6	5/8	0.85	3.03	6.5	1.53
XGA3	8.125	8	5/8	0.85	3.59	7	1.69
XGA3.5	9.5	8	3/4	1.06	4.19	7.5	1.88
XGA4	11	8	3/4	1.06	4.75	8.25	2.16
XGA4.5	12	10	3/4	1.06	5.31	9	2.56
XGA5	13.5	8	7/8	1.45	6.03	9.5	2.94
XGA5.5	14.5	14	7/8	1.45	6.91	10.5	3.19
XGA6	15.75	14	7/8	1	7.41	SU RICHIESTA available on demand	
XGA7	18.25	16	1	1.12	8.69		

## 21.31 GIUNTO A DENTI A TAMBURO - DRUM GEAR COUPLING

TIPO - TYPE

XGD<sub>xxx</sub>

### CARATTERISTICHE E COMPOSIZIONE

I giunti a denti a tamburo EPR, serie XGD, sono composti di:

- Un manicotto a denti semicircolare
- Un mozzo dentato con dentatura bombata
- Guarnizioni speciali per garantire la perfetta tenuta della parte interna, impedendo ingresso di polvere e di uscita di grasso
- Speciale rivestimento interno
- Ingrassatore

### VANTAGGI

- PROGETTAZIONE
- SINGOLO DENTE RINFORZATO
- DURATA MAGGIORE
- MAGGIORE CAPACITA' DI CARICO
- MAGGIORE COPPIA TRASMISSIBILE
- GAMMA DIMENSIONI COMPLETA



### FEATURES & COMPOSITION

EPR drum couplings, XGD series, are composed of:

- One semicircular gear sleeve
- One gear hub with developed toothing
- Special seals to ensure the perfect tightness of the inner part, preventing inlet of dust and outlet of grease
- Special inner cover
- Grease nipple

### ADVANTAGES

- DEVELOPED DESIGN
- STRONGER INDIVIDUAL TOOTH
- LONGER LIFETIME
- HIGHER LOAD CAPACITY
- HIGHER TRANSMITTABLE TORQUE
- FULL RANGE OF SIZES

### APPLICAZIONE - APPLICATION

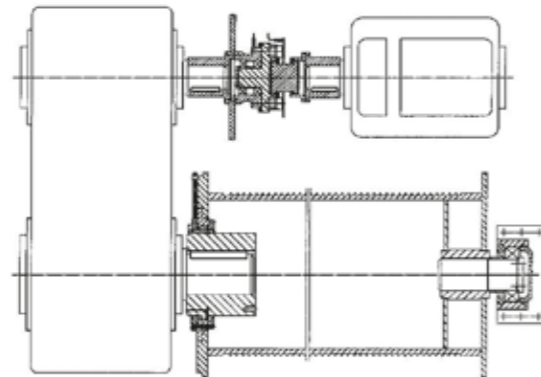

- I giunti a denti a tamburo EPR sono tipicamente adatti per l'installazione in meccanismi di sollevamento e gru, per collegare il tamburo del cavo con l'albero di uscita del riduttore, così come nei verricelli e montacarichi a piattaforma.
- I giunti a denti a tamburo EPR, installato tra il riduttore e tamburo, svolgono la funzione di uno snodo, in modo da rendere il collegamento staticamente definito ed evitando l'insorgere di momenti elevati.
- Dal punto di vista del design, siamo in grado di garantire una più lunga durata, grazie alla nostra dentatura a denti ridisegnata, in combinazione con il nostro lubrificante speciale, che essenzialmente si distingue dagli altri per la base ad olio.

- EPR drum gear couplings are typically suitable for installation in lifting mechanisms and drum drives of cranes, to connect the cable drum with the gearbox output shaft, as well as in winch conveyors and platform hoists.
- EPR drum gear couplings, installed between the gearbox and cable drum, perform the function of an articulated joint, in order to make the connection statically determinate and avoiding the occurrence of high bending moments.
- From the design point of view, we can grant longer lifetime, due to our developed gear toothing, in combination with our special lubricant, which distinguishes itself from the others in terms of the oil base, essentially.

### FORATURA FLANGE - FLANGE DRILLING

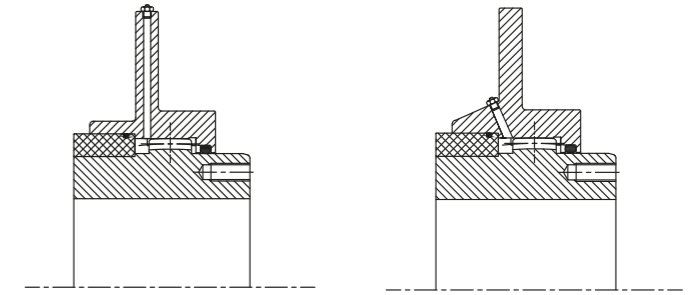
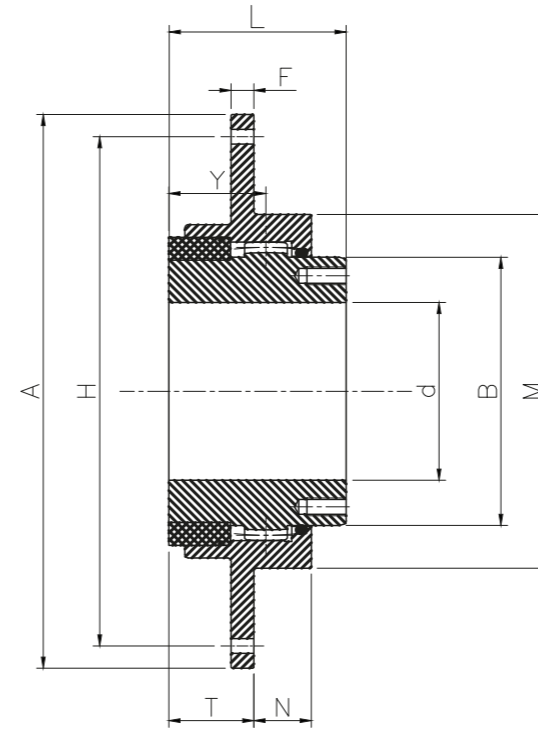
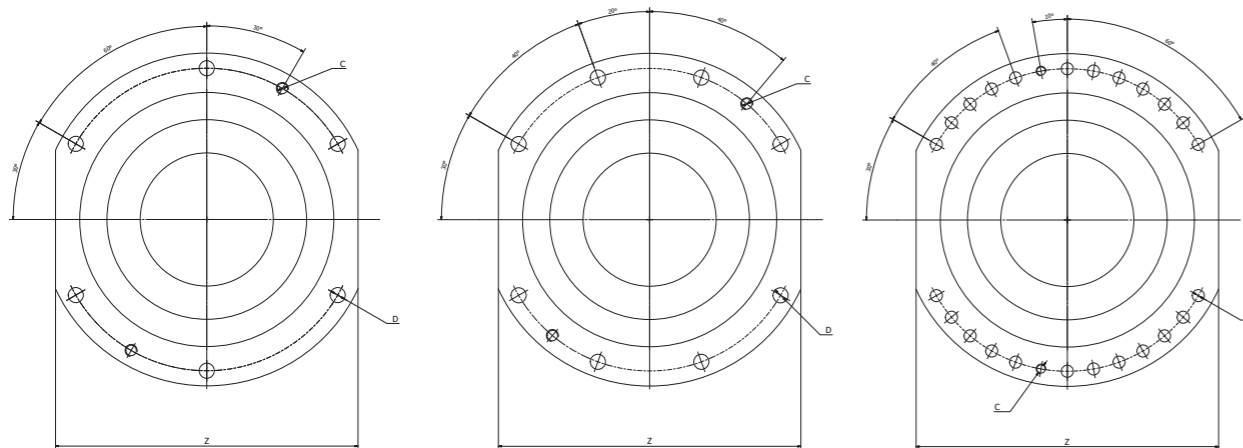

Z=numero fori / number of holes

### DATI E DIMENSIONI - TECHNICAL DATA

TYPE SIZE	NOMINAL TORQUE T <sub>n</sub> [kNm]	MAX. TORQUE T <sub>cs</sub> [kNm]	MAX. LOAD Q <sub>o</sub> [Kg]	MAX. BORE d [mm]	A [mm]	H [mm]	M [mm]	B [mm]	L [mm]	Z [mm]	WEIGHT [Kg]
XGD280	22.2	33.3	3600	100	320	280	200	149	110	6	28
XGD300	27.5	41.3	4050	110	340	300	220	165	125	6	36
XGD320	34.1	51.2	4500	120	360	320	240	184	130	6	44
XGD340	46.2	69.3	5500	130	380	340	260	196	145	6	53
XGD360	61	92	6750	150	400	360	280	222	170	6	73
XGD380	83	125	8300	165	420	380	310	253	175	6	96
XGD400	97	146	11300	175	450	400	340	266	185	6	120
XGD460	146	219	14600	210	510	460	400	317	220	6	158
XGD500	168	252	16000	220	550	500	420	330	240	6	223
XGD530	205	443	18200	245	580	530	450	368	260	8	284
XGD600	352	528	22500	290	650	600	530	435	315	8	466
XGD630	380	570	25400	305	680	630	560	460	350	24	574
XGD670	475	713	29400	330	710	670	600	500	380	24	718
XGD730	593	890	35800	375	780	730	670	560	410	24	956
XGD800	708	1062	42000	410	850	800	730	610	450	24	1230



## 23. INSTALLAZIONE, MANUTENZIONE & LUBRIFICAZIONE

## INSTALLATION, MAINTENANCE & LUBRICATION

Istruzione per l'installazione:

1. Smontare il giunto nei suoi componenti principali mozzi e campane.
2. Assicurarsi che tutti i componenti siano puliti.
3. Inserire le campane o le flange porta guarnizioni sugli alberi.
4. Eseguire il calettamento dei mozzi sugli alberi, se si procede al riscaldamento dei mozzi, non superare mai la temperatura di 170°C.
5. Per garantire una durata ottimale del giunto è necessario eseguire l'allineamento degli alberi in modo scrupoloso, come indicato di seguito. Per eseguire l'allineamento utilizzare un comparatore fisso su uno dei due mozzi e farlo ruotare sull'altro mozzo (fig. 8): la lettura del valore diviso per due dà il valore del disallineamento parallelo. Il disallineamento angolare va controllato con un comparatore fissato su un mozzo e fatto ruotare sulla facciata dell'altro mozzo (fig. 8), oppure controllato con spessore in almeno tre posizioni a 120°C (fig. 9). Nel caso di installazione di giunti completi di allunghe, eseguire l'allineamento mediante laser; se non fosse possibile l'utilizzo del laser, seguire le istruzioni secondo la figura 10.
6. Eseguito l'allineamento degli alberi, procedere alla lubrificazione delle guarnizioni e al montaggio delle campane sui mozzi.
7. Unire le due campane mediante le apposite viti fornite con il giunto e serrarle alle coppie riportate in figura 11.

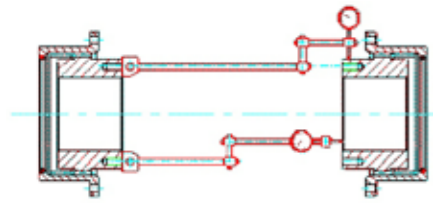

fig. 8

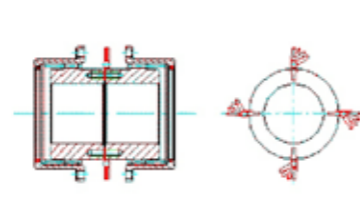

fig. 9

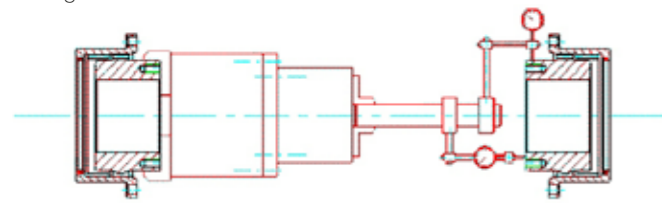

fig. 10

fig. 11

SIZE	Coppia di serraggio [Nm]	Interassi fori della flangia [mm]	Numero viti	Foro flangia H8 - d8
XGS111.D	18	96	6	8/M8
XGS142.D	36	122	8	10/M10
XGS168.D	36	148	10	10/M10
XGS200.D	65	178	10	12/M12
XGS225.D	65	203	12	12/M12
XGS265.D	150	236	12	16/M16
XGS300.D	150	270	14	16/M16
XGS330.D	150	300	14	16/M16
XGS370.D	220	335	14	18/M18
XGS406.D	400	368	14	22/M22
XGS439.D	400	400	14	22/M22
XGS505.D	520	460	16	24/M24

8. Per ottenere un'adeguata durata del giunto, la lubrificazione corretta è un passaggio fondamentale; inserire il grasso nel giunto tramite gli ingrassatori posti sulle campane fino al totale riempimento dello stesso, pompando dal foro inferiore finché non si noterà la fuoriuscita del grasso dal foro superiore. Nei periodi immediatamente dopo la prima installazione, eseguire la lubrificazione ogni due mesi, in seguito ogni quattro mesi. Ogni 10.000 ore o due anni di lavoro, eseguire la totale sostituzione del grasso.

I giunti EPR vengono forniti non lubrificati.

Se il giunto è equipaggiato da allungia autolubrificante è necessario eseguire il riempimento solo una volta l'anno, la stessa provvederà a distribuirlo in modo automatico e uniforme al giunto. Il lubrificante più adatto per il buon funzionamento del giunto a denti EPR deve rispettare le caratteristiche indicate nella seguente tabella:

### CARATTERISTICHE LUBRIFICANTE

Addensante: Litio complesso  
 Grado NLGI: 2  
 Campo d'impiego della temperatura: - 30°C + 160°C  
 Penetrazione a 25°C: 265 - 295 (0.1 mm)  
 Prestazione antiruggine: SI  
 Punto di goccia: > 260°C  
 Viscosità olio base a 40°C: 340 mm<sup>2</sup>/s (cSt)

Instructions for installation:

1. Disassemble the EPR gear coupling into its main components hubs and sleeves.
2. Ensure that all components are clean.
3. Place the sleeves or flanges seal covers on the shafts.
4. Run the pitch of the hubs on the shafts, if you proceed to heating of the hubs, never exceed a temperature of 170°C.
5. To ensure optimum lifetime of EPR gear coupling is necessary to perform the alignment of the shafts in a scrupulous way. To perform the alignment, use a comparator fixed on one of the two hubs and make it rotate on the other hub (fig.8), reading the value divided by two gives the value of the parallel misalignment. The angular misalignment must be checked with a comparator fixed on a hub and made to rotate on the facade of the other hub (fig.8), or with controlled thickness gauge in at least three position at 120°C (fig.9). In case of installation of gear couplings complete with extensions run laser alignment, if you can not use the laser, follow the instructions according to the figure 10.
6. After the shaft alignment is executed, proceed with the lubrication of the seals and the installation of the sleeves on the hubs.
7. Put together the sleeves using the screws provided with the gear coupling, that have to be tightened at the proper torque.(see fig.11)

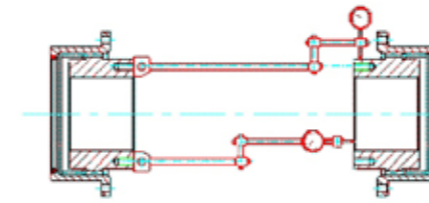

fig. 8

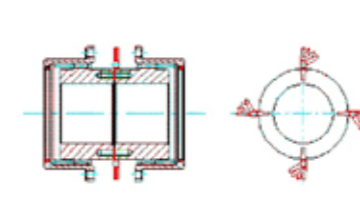

fig. 9

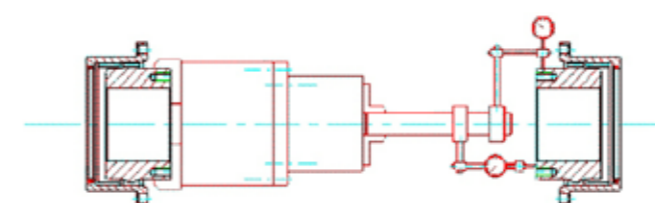

fig. 10

fig. 11

SIZE	Tightening torque [Nm]	Distance between hole centers [mm]	N. of holes	Hole diameter H8 - d8
XGS111.D	18	96	6	8/M8
XGS142.D	36	122	8	10/M10
XGS168.D	36	148	10	10/M10
XGS200.D	65	178	10	12/M12
XGS225.D	65	203	12	12/M12
XGS265.D	150	236	12	16/M16
XGS300.D	150	270	14	16/M16
XGS330.D	150	300	14	16/M16
XGS370.D	220	335	14	18/M18
XGS406.D	400	368	14	22/M22
XGS439.D	400	400	14	22/M22
XGS505.D	520	460	16	24/M24

8. To obtain an adequate lifetime of the coupling, the proper lubrication is a critical step: run the filling through the grease nipples places on the sleeves until total filling of the same. In the periods immediately after the start-up, lubricate every two months, then every four months. Every two years or 10,000 hours of operation, perform the complete replacement of the grease.

The EPR gear couplings are supplied with no lubricant.

If the coupling is equipped with self-lubricating device you need to fill only once a year, the same will automatically be distributing it evenly to the joint.

Suitable lubricants for the proper functioning of the gear coupling EPR respects the features indicated below:

### LUBRICANT FEATURES

Thickener: Lithium complex  
 NLGI Grade: 2  
 Application range of temperature: - 30°C + 160°C  
 Penetration at 25°C: 265 - 295 (0.1 mm)  
 Anti-rust performance: YES  
 Dropping Point: > 260°C  
 Base oil viscosity at 40°C: 340 mm<sup>2</sup>/s (cSt)

## 22. ALLUNGHE MILL SERIE XZ

Dalla perfezione nella realizzazione delle nostre dentature bombate nasce la serie XZ, allunghe a denti ad albero passante, caratterizzata dalla massima cura nella scelta dei materiali, nei trattamenti termici e nell'assemblaggio. Come risultato siamo riusciti ad ottenere un prodotto dalla massima affidabilità e durata nel tempo.

### MILL GEAR SPINDLE XZ SERIES

*The perfection in the realization of our gears rounded born XZ series, gear spindles with hollow shaft, characterized by the extreme care in the selection of materials, heat treatment and assembly. As result we obtained a product with maximum reliability and long life.*



WE  
SPIN  
YOUR  
WORLD



Oscar Leciñana  
*Ingeniero Industrial*

Tfno.: +34 946 61 53 10  
Móvil.:+34 696 20 65 66

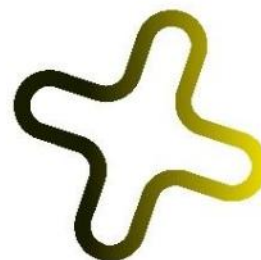

**CardanPlus**

C/Lezama Leguizamón, 11 - Local •48450 Etxebarri  
[comercial@cardanplus.com](mailto:comercial@cardanplus.com) - [www.cardanplus.com](http://www.cardanplus.com)